

Designed for ease of integration, the **Keytroller II/Slimtroller II** reader/writers are single board, serial Key/Token interface units that connect quickly to host hardware via a standard RS-232 port or USB port. Lightweight and space-saving, the unit includes communication cable and mounting accessories. The Keytroller II/Slimtroller II supports either RS-232 or USB serial interface communication between the serial data Keys/Tokens and their host with a simple protocol. They support interchangeable use of serial memory Keys and Tokens for applications in data security, automatic identification, data collection, and more. **Optional faceplate is available.** For applications with limited space available immediately behind the control panel, the **Unitroller II** supports remotely connecting a panel-mount Keyceptacle[®] or Receptacle via a ribbon cable.

Mechanical	
Contact Life (Socket)	Keytroller II: 200,000 Slimtroller II: 50,000 Insertion/removal cycles minimum
Drop Shock	32" drop on carpet-covered concrete Repeated three times on each axis
Electrical	
Power Requirements	9 VDC @ 50mA external power supply for RS-232 interface. USB power for USB versions
I/O Connector	9-pin "D" style female for RS-232 USB B female for USB
Environmental	
Storage Temperature	-40° C to 85° C
Operating Temperature	0° C to 70° C
Relative Humidity	5% to 95% (non-condensing)
Supplied Accessories	
Manual	DB9 to DB9 communication cable (RS-232) or 6'6" (2m) USB cable (USB).
Mating Component(s)	
Keys or Tokens	Serial Memory Keys/Tokens
Keytroller II Faceplate	326-0181-003A
Slimtroller II Faceplate	326-0181-006A
Ordering Information ¹	
Keytroller IIs (RS-232)	607-0066-000A
Keytroller IIs (USB)	607-0066-001A
Slimtroller IIs (RS-232)	607-0076-000A
Slimtroller IIs (USB)	607-0076-001A
Unitroller IIs (RS-232)	607-0069-001A
Unitroller IIs (USB)	607-0069-000A

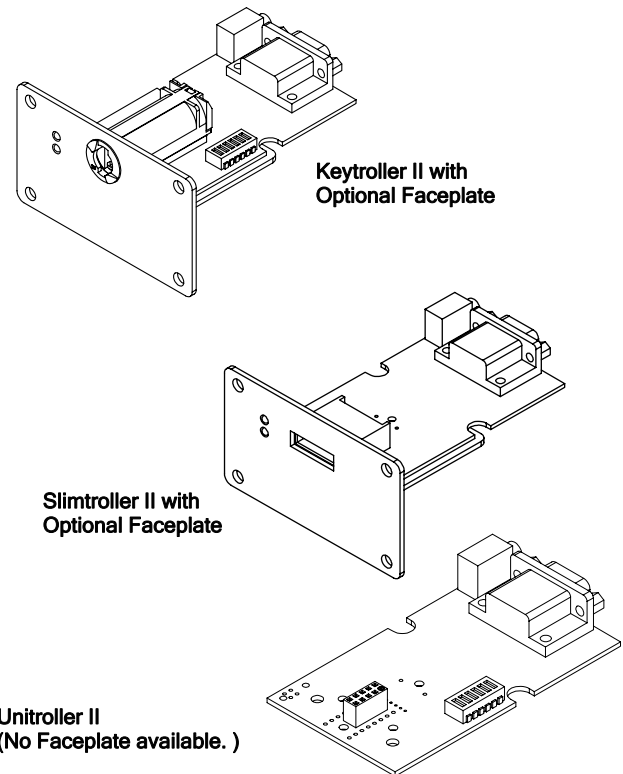

See next 3 pages for mechanical drawings.

RS-232 Communications Protocol ²	
Data length	8 bits
Stop bits	1 bit
Parity type	Even/Odd/None
Baud rate	2400, 4800, 9600, 19200 baud
Bit order	LSB first

RS-232 Pin-Out Chart		
Pin #	Function	Signal
1	No Connection	
2	Data From Reader	TXD
3	Data to Reader	RXD
4	No Connection	
5	Signal Ground	GND
6	No Connection	
7	No Connection	
8	CTS from Reader	CTS
9	No Connection	

NOTES:

- 1: "A" suffix on part number indicates RoHS compliance.
- 2: The factory default settings are 9600 baud, no parity and 1 stop bit.



Keytroller™ II Reader/Writer Also Slimtroller™ II & Unitroller™ II

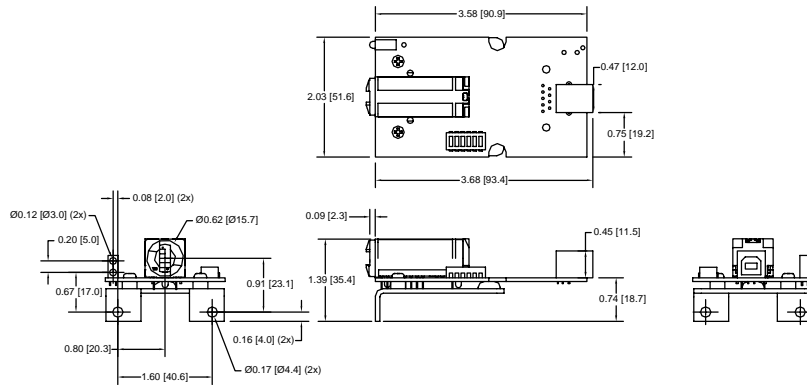

Keytroller™ II

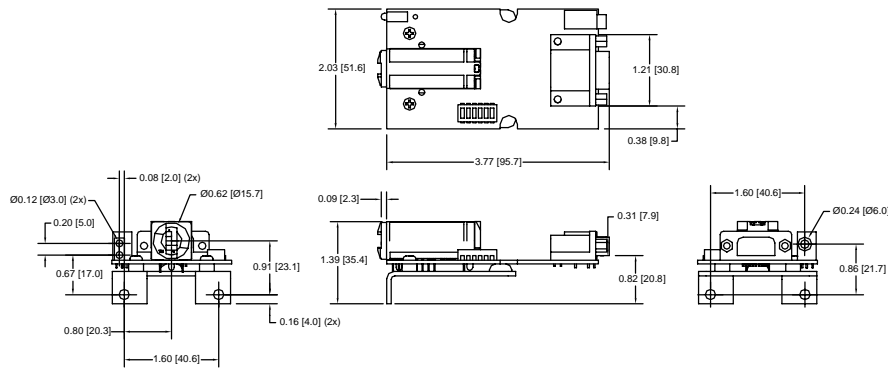

Keytroller™ IIu

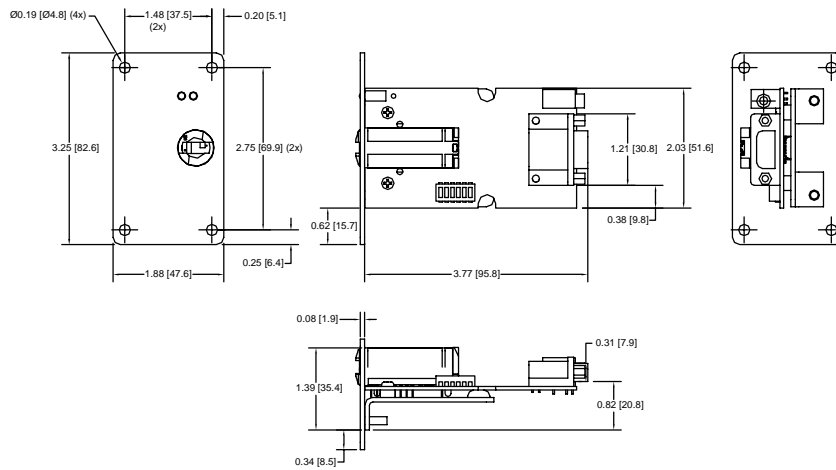

Optional Keytroller™ II Faceplate

Drawing dimensions are in inches and millimeters [mm]. Dimensions are nominal and subject to manufacturer's tolerances.



Keytroller™ II Reader/Writer Also Slimtroller™ II & Unitroller™ II

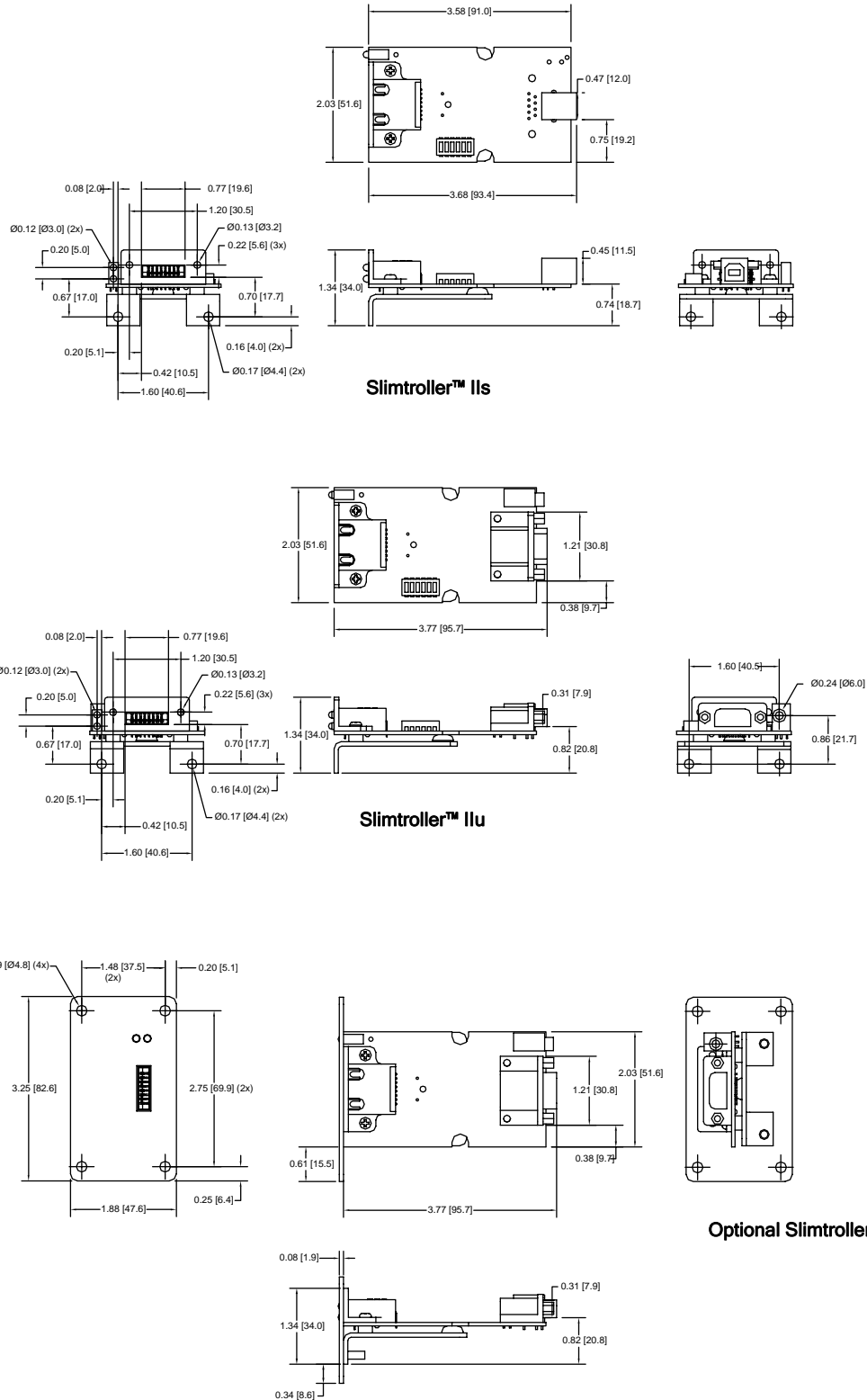

Drawing dimensions are in inches and millimeters [mm]. Dimensions are nominal and subject to manufacturer's tolerances.



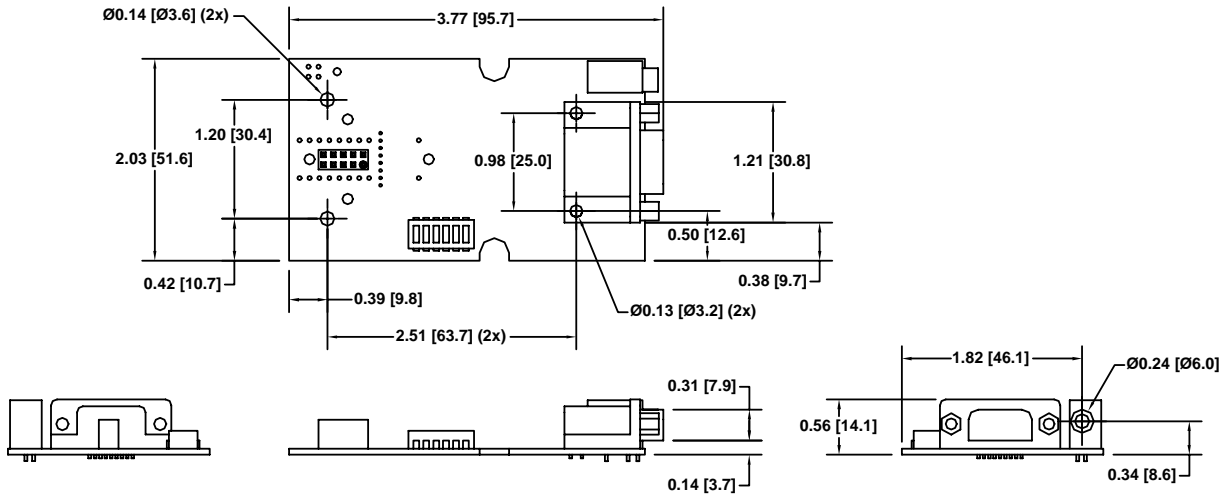

Unitroller™ IIs

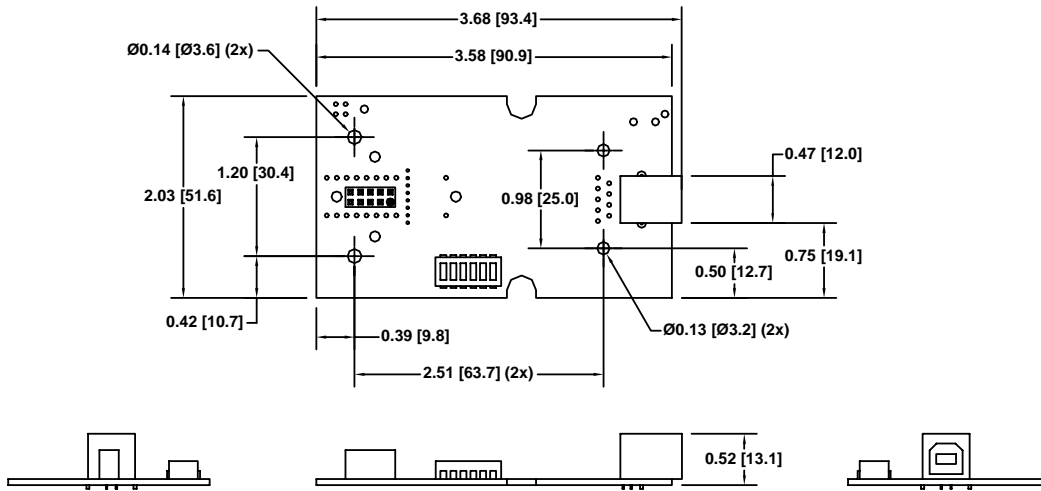

Unitroller™ IIu

Drawing dimensions are in inches and millimeters [mm]. Dimensions are nominal and subject to manufacturer's tolerances.

